

Dimensions & Weight

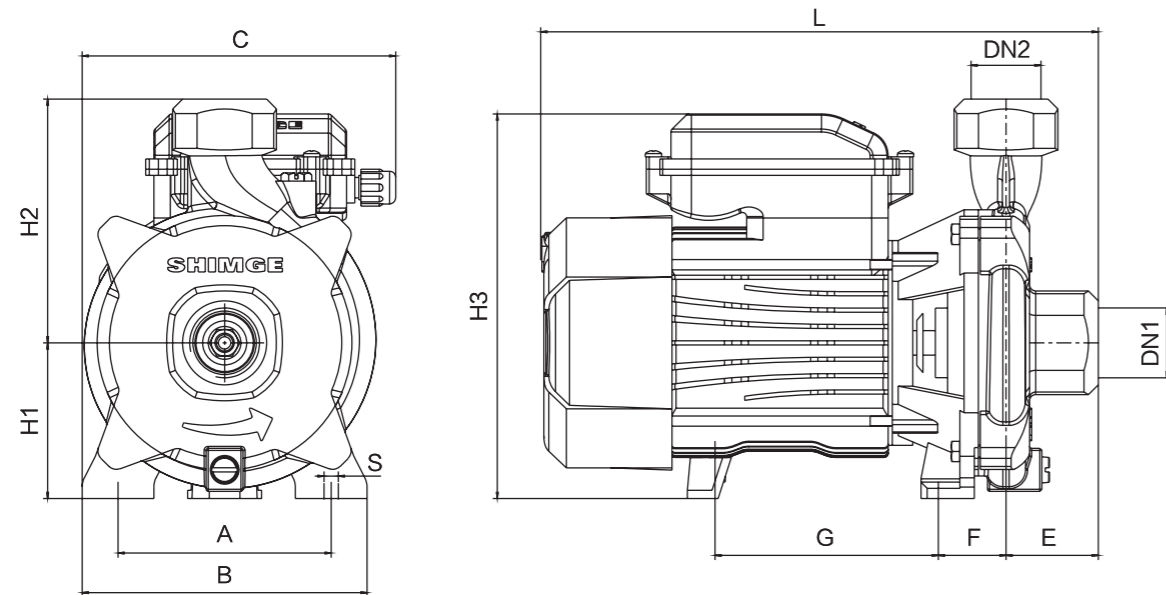

Model	DN1	DN2	Dim.(mm)										N.W. (kg)	
			(Inch)		A	B	C	E	F	G	L	S		H1
PUM200	1	1	104	139	153	45	33	109	272	7	76	119	188	7.5
PUM400	1	1	131	172	176	43	39.5	130	309	10	95	125	220	11.5
PUM600	1	1	131	172	177.5	53.5	39.5	130	320	10	98	135	223	13

Packing Size & Weight

Model	Dim.(L×W×H)	G.W. (kg)	20'Loading Qty. (pcs)
PUM200	310×205×240	8	1881
PUM400	380×235×285	12	1232
PUM600	380×235×285	13.5	1232

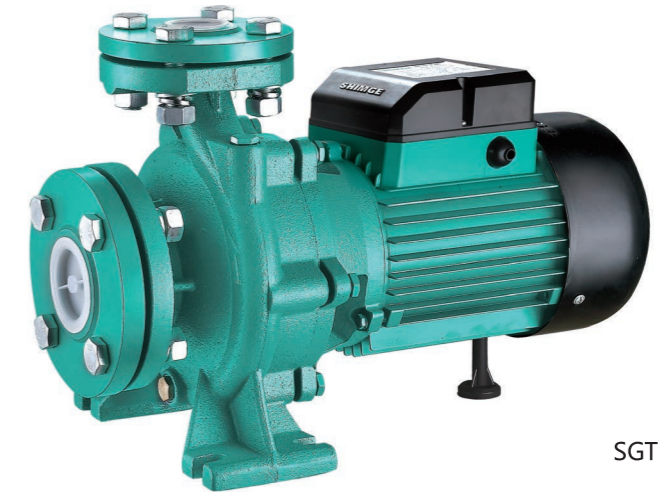
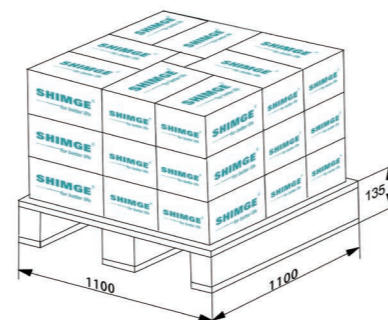

SGT

Model Instruction

SGT 32-160/1.5

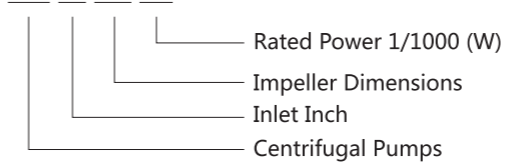

Applications Fields

- ◉ Suitable for transferring water without abrasive particles or other liquid whose properties are similar to water.
- ◉ Widely used in industrial and urban water supply, high-rise building boosting, fire protection system, breeding

Performance Range

- ◉ Max. Flow: 39m³/h
- ◉ Max. Head: 52m

Features

- ◉ Standard flange centrifugal pump
- ◉ Large flow, high efficiency

Application Limits

- ◉ Suction head up to 8m
- ◉ Liquid temperature up to +60°C
- ◉ Ambient temperature up to +40°C
- ◉ Max. Working pressure: 6bar
- ◉ Voltage fluctuation should not exceed 10% of rated value.
- ◉ pH: 6.5 to 8.5

Motor

- ◉ Three-Phase 380V/50Hz
- ◉ Motor: 2 pole asynchronous motor, copper wires, built-in thermal protector, fully closed fan cooling, continuous running
- ◉ Protection: IP44
- ◉ Insulation: Class B

Certificate



Optional Available on Request

- (* Standard configuration on Page 36)
- ◉ Motor whose insulation class is F
- ◉ NSK bearing

Performance Curve

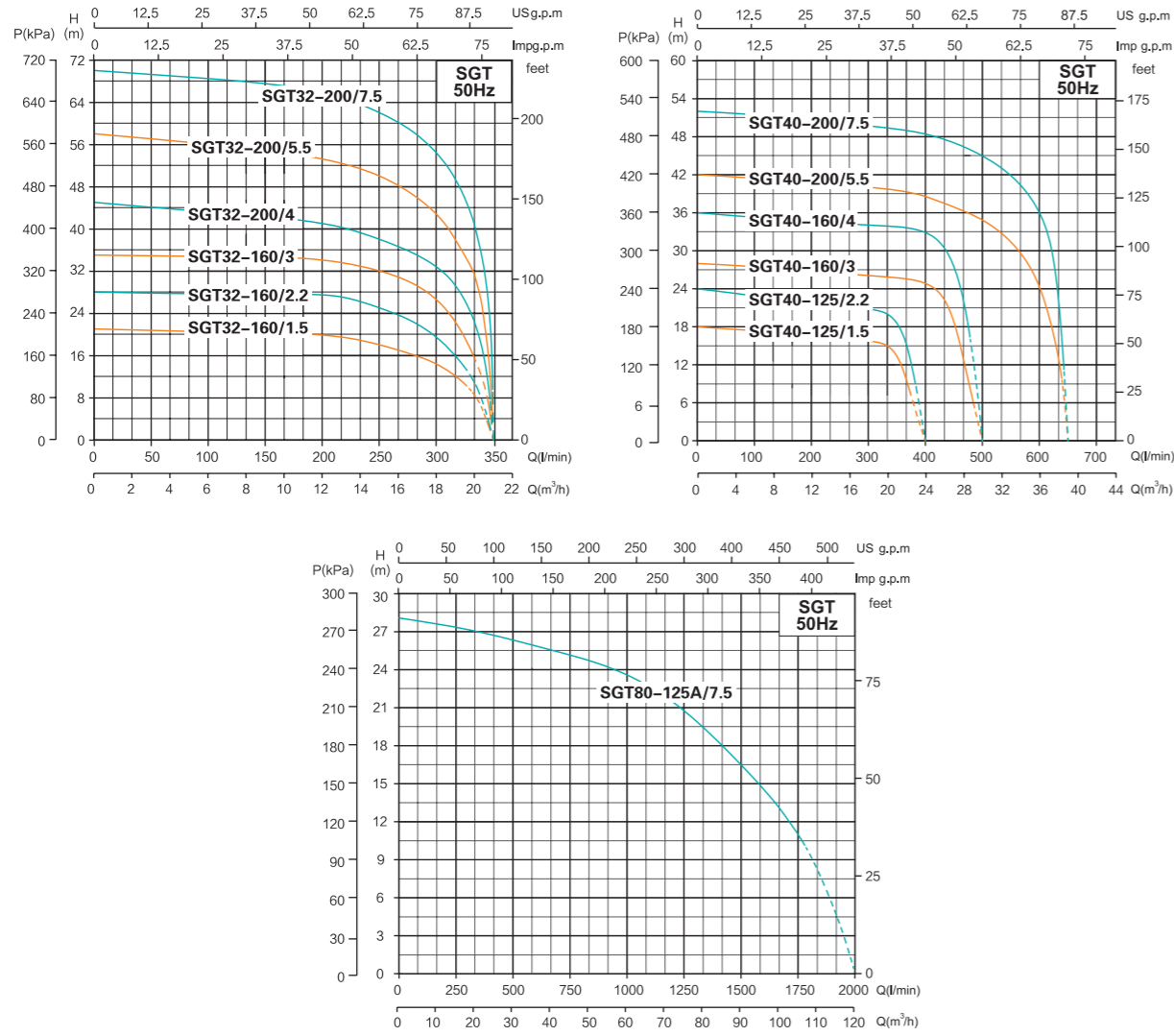

Model	Power		Max. Flow (m ³ /h)	Max. Head (m)	Head Range (m)	Max. Suction (m)
	kW	HP				
SGT32-160/1.5	1.5	2	21	21	10~21	8
SGT32-160/2.2	2.2	3	21	28	14~28	8
SGT32-160/3	3	4	21	35	16~35	8
SGT32-200/4	4	5.5	21	45	7~45	8
SGT32-200/5.5	5.5	7.5	21	58	8~58	8
SGT32-200/7.5	7.5	10	21	70	10~70	8
SGT40-125/1.5	1.5	2	24	18	7~18	8
SGT40-125/2.2	2.2	3	24	24	9~24	8
SGT40-160/3	3	4	30	28	6~28	8
SGT40-160/4	4	5.5	30	36	17~36	8
SGT40-200/5.5	5.5	7.5	39	42	10~42	8
SGT40-200/7.5	7.5	10	39	52	11~52	8
SGT80-125A/7.5	7.5	10	120	28	10~28	8

Components & Materials

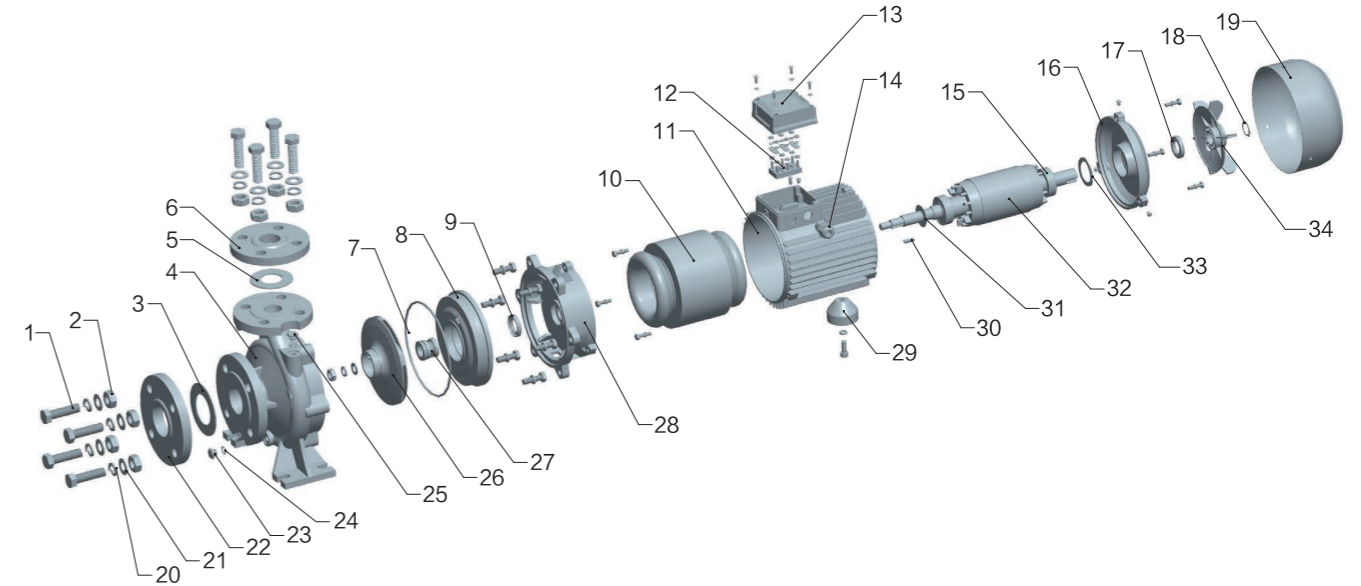

No.	Component	No.	Component	No.	Component
1	Tie-Bolt	13	Terminal Block Cover	25	Air Faucet
2	Nut	14	Cable Locking Head	26	Impeller
3	Rubber	15	Bearing	27	Mechanical Seal
4	Pump Body	16	End Cover	28	Coupling
5	Rubber	17	Oil Seal	29	Foot
6	Flange	18	Shaft Circlip	30	Key
7	O-ring	19	Fan Cover	31	Waterproof Ring
8	Pump Cover	20	Spring Gasket	32	Rotor
9	Oil Seal	21	Washer	33	Wave Spring
10	Stator	22	Flange	34	Fan
11	Motor Case	23	Water Faucet		
12	Terminal Board	24	O-ring		

NO.	Power (kW)	1.5	2.2	3	4	5.5	7.5
15	End-cover	6204-2RS/C3Z2	6204-2RS/C3Z2	6205-2RS/C3Z2	6206-2RS/C3Z2	6206-2RS/C3Z2	6208-2RS/C3Z2
	bearing	6205-2RS/C3Z2	6205-2RS/C3Z2	6205-2RS/C3Z2	6206-2RS/C3Z2	6206-2RS/C3Z2	6208-2RS/C3Z2
	Coupling bearing	304+Steel 45#					
27	Motor shaft	701-20/29 S:K(P)Stationary seal ring ø35			701-25/31 S:K(P)Stationary seal ring ø40		701-28/32 S:K(P)Stationary seal ring ø40
	Mechanical seal	S:RBSC K: Ceramic P:NBR					
11	Motor Case	Aluminum					
28	Coupling	Cast Iron					
4	Pump body	Cast Iron					
26	Impeller	Cast Iron					
8	Pump Cover	Cast Iron					

Dimensions & Weight

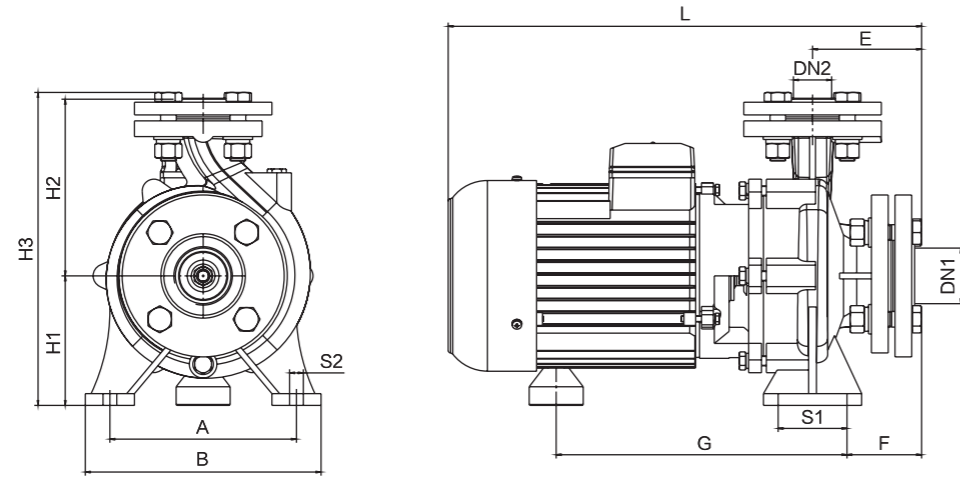

Model	DN		Dim.(mm)										N.W. (kg)	
	DN1 (Inch)	DN2 (Inch)	A	B	E	F	G	L	S1	S2	H1	H2		H3
SGT32-160/1.5	2	1.25	190	240	111	76	272	441	70	14	132	180	319	32
SGT32-160/2.2	2	1.25	190	240	111	76	280	476	70	14	132	180	319	37
SGT32-160/3	2	1.25	190	240	111	76	296	482	70	14	132	180	319	40
SGT32-200/4	2	1.25	190	240	111	76	289	511	70	14	160	200	367	52
SGT32-200/5.5	2	1.25	190	240	111	76	299	532	70	14	160	200	367	63.5
SGT32-200/7.5	2	1.25	190	240	111	76	316	581	70	14	160	200	367	74
SGT40-125/1.5	2.5	1.5	160	210	112	77	272	442	70	14	112	162	281	31
SGT40-125/2.2	2.5	1.5	160	210	112	77	280	477	70	14	112	162	281	40
SGT40-160/3	2.5	1.5	175	210	112	77	301	488	70	14	132	182	321	43
SGT40-160/4	2.5	1.5	175	210	112	77	291	514	70	14	132	182	321	51
SGT40-200/5.5	2.5	1.5	215	265	132	97	296	550	70	14	160	202	369	61
SGT40-200/7.5	2.5	1.5	215	265	132	97	313	599	70	14	160	202	369	73.5
SGT80-125A/7.5	4	3	215	265	132	97	313	599	70	14	160	202	369	84.5

Packing Sizes & Weight

Model	Dim.(L×W×H) mm	G.W. (kg)	20'Loading Qty. (pcs)
SGT32-160/1.5	490×285×355	35	616
SGT32-160/2.2	520×285×355	40	568
SGT32-160/3	595×275×355	43	556
SGT32-200/4	600×315×405	57	371
SGT32-200/5.5	660×315×405	68.5	336
SGT32-200/7.5	660×315×405	79	336
SGT40-125/1.5	490×255×315	34	774
SGT40-125/2.2	520×255×315	40	738
SGT40-160/3	625×275×355	48	480
SGT40-160/4	645×275×355	56	456
SGT40-200/5.5	655×300×415	66	350
SGT40-200/7.5	735×300×415	83.5	324



Performance Range

- Max. Flow: 6m³/h
- Max. Head: 80m

Application Limits

- Suction head up to 9m
- Liquid temperature up to +40°C
- Ambient temperature up to +40°C
- Max. Working pressure: 5bar
- Voltage fluctuation should not exceed 10% of rated value.
- pH: 6.5 to 8.5

Certificate



Applications Fields

- Suitable for transferring water without abrasive particles or other liquid whose properties are similar to water.
- Widely used in living water supply, water tower water supply, well water lifting, automatic irrigation system, various corollary equipment, etc.

Features

- The JET type self-priming pump
- High suction, with short time
- Different impeller material configuration

Motor

- Single-Phase 220V/50Hz
- Three-Phase 380V/50Hz
- Motor: 2 pole asynchronous motor, copper wires, built-in thermal protector, fully closed fan cooling, continuous running
- Protection: IP44
- Insulation: Class B

Optional Available on Request

- (* Standard configuration on Page 40)
- 304 stainless steel welding shaft
- Electrophoretic pump body and connections
- NSK bearing
- Motor whose insulation class is F
- Other voltage or frequency is 60Hz



JET-A



JET-L



JET100P



JET300/400

Model Instruction

