

Performance Curve - BL(T)32

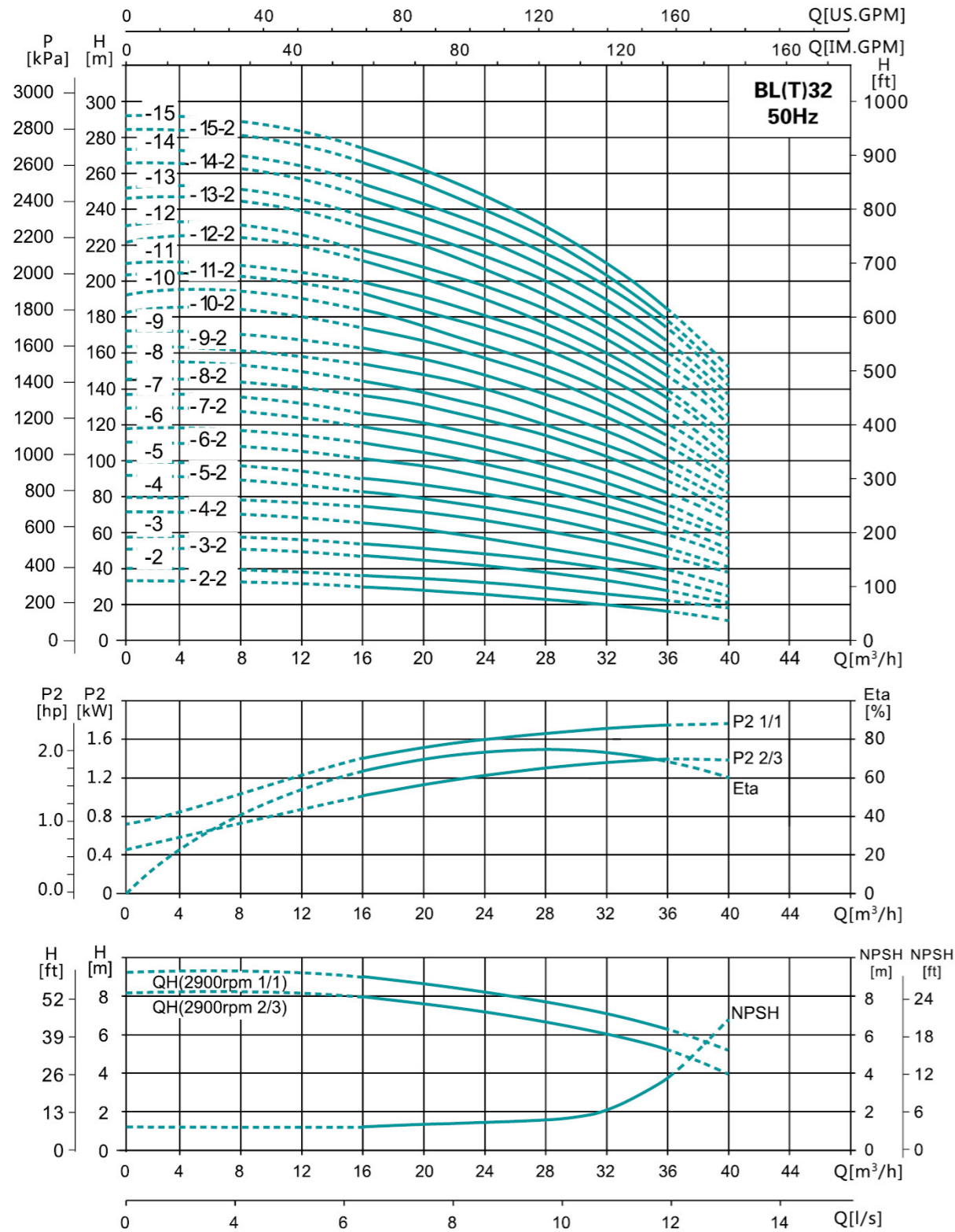

It is recommended to be used within lift range.

Performance Table

Model	Power		Q (m³/h)	H (m)							Head Range (m)
	kW	HP		16	20	24	28	32	36		
BL(T)32-2-2	3	4	29	28	26	23	20	16	16~29		
BL(T)32-2	4	5.5	36	34	32	29	27	23	23~36		
BL(T)32-3-2	5.5	7.5	47	44	41	38	33	28	28~47		
BL(T)32-3	5.5	7.5	54	51	48	44	40	35	35~54		
BL(T)32-4-2	7.5	10	65	62	58	53	46	40	40~65		
BL(T)32-4	7.5	10	72	69	65	59	53	47	47~72		
BL(T)32-5-2	11	15	83	79	74	68	60	52	52~83		
BL(T)32-5	11	15	90	86	81	74	67	59	59~90		
BL(T)32-6-2	11	15	101	97	90	83	74	65	65~101		
BL(T)32-6	11	15	108	104	97	90	81	72	72~108		
BL(T)32-7-2	15	20	119	114	107	98	88	78	78~119		
BL(T)32-7	15	20	126	121	113	105	95	85	85~126		
BL(T)32-8-2	15	20	136	131	123	114	102	90	90~136		
BL(T)32-8	15	20	144	138	130	120	109	97	97~144		
BL(T)32-9-2	18.5	25	154	148	140	129	117	102	102~154		
BL(T)32-9	18.5	25	162	156	147	136	124	109	109~162		
BL(T)32-10-2	18.5	25	175	166	157	146	131	115	115~175		
BL(T)32-10	18.5	25	182	173	164	152	138	122	122~182		
BL(T)32-11-2	22	30	193	184	173	164	146	128	128~193		
BL(T)32-11	22	30	200	191	180	168	153	135	135~200		
BL(T)32-12-2	22	30	211	201	189	178	160	140	140~211		
BL(T)32-12	22	30	218	208	196	184	167	147	147~218		
BL(T)32-13-2	30	40	230	218	206	193	174	153	153~230		
BL(T)32-13	30	40	237	225	213	200	181	160	160~237		
BL(T)32-14-2	30	40	247	235	222	210	189	165	165~247		
BL(T)32-14	30	40	255	242	229	216	196	172	172~255		
BL(T)32-15-2	30	40	266	253	239	224	203	178	178~266		
BL(T)32-15	30	40	274	260	246	231	210	185	185~274		

Dimensions & Weight

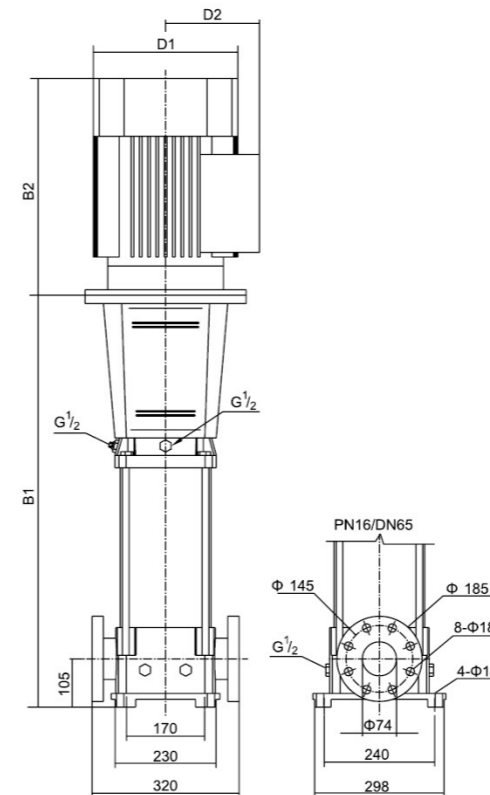

Model	Dim.(mm)					N.W.(kg)
	B1	B2	B1+B2	D1	D2	
BL(T)32-2-2	634	325	959	191	140	74/78
BL(T)32-2	634	355	989	212	163	81/85
BL(T)32-3-2	724	395	1119	258	163	100/104
BL(T)32-3	724	395	1119	258	163	100/104
BL(T)32-4-2	794	395	1189	258	163	106/110
BL(T)32-4	794	395	1189	258	163	106/110
BL(T)32-5-2	894	498	1392	315	251	185/189
BL(T)32-5	894	498	1392	315	251	185/189
BL(T)32-6-2	964	498	1462	315	251	189/193
BL(T)32-6	964	498	1462	315	251	189/193
BL(T)32-7-2	1034	498	1532	315	251	203/207
BL(T)32-7	1034	498	1532	315	251	203/207
BL(T)32-8-2	1104	498	1602	315	251	207/211
BL(T)32-8	1104	498	1602	315	251	207/211
BL(T)32-9-2	1174	542	1716	315	251	228/232
BL(T)32-9	1174	542	1716	315	251	228/232
BL(T)32-10-2	1244	542	1786	315	251	232/236
BL(T)32-10	1244	542	1786	315	251	232/236
BL(T)32-11-2	1314	578	1892	355	267	278/282
BL(T)32-11	1314	578	1892	355	267	278/282
BL(T)32-12-2	1384	578	1962	355	267	281/286
BL(T)32-12	1384	578	1962	355	267	281/286
BL(T)32-13-2	1454	669	2123	397	299	361/365
BL(T)32-13	1454	669	2123	397	299	361/365
BL(T)32-14-2	1524	669	2193	397	299	364/369
BL(T)32-14	1524	669	2193	397	299	364/369
BL(T)32-15-2	1594	669	2263	397	299	368/373
BL(T)32-15	1594	669	2263	397	299	368/373