

Performance Curve - BL(T)20

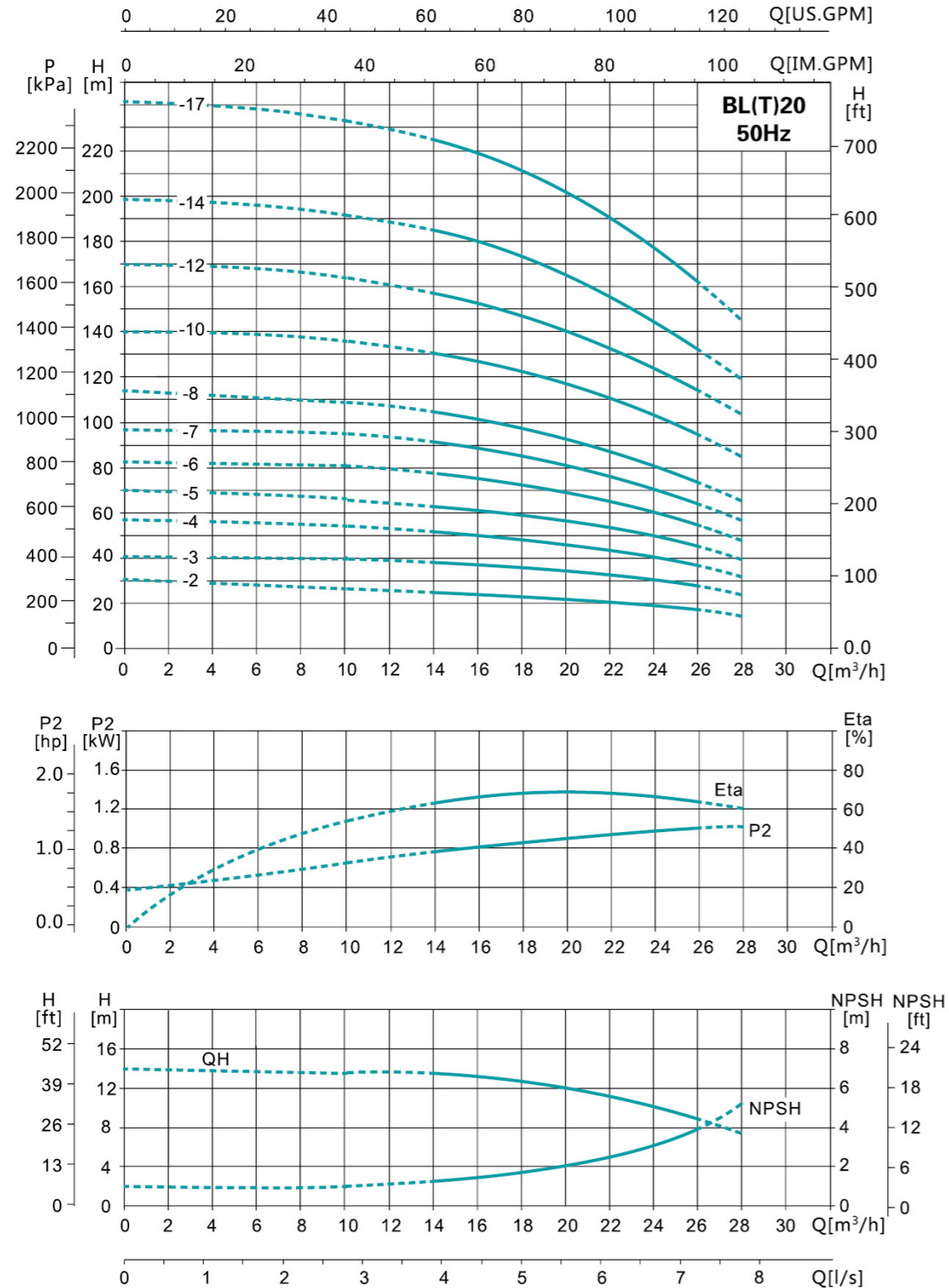

It is recommended to be used within lift range.

Performance Table

Model	Power		Q (m³/h)	14	16	18	20	22	24	26	Head Range (m)
	kW	HP									
BL(T)20-2	2.2	3	H (m)	27	25	24	23	22	20	18	18~27
BL(T)20-3	4	5.5		40	38	37	35	33	30	27	27~40
BL(T)20-4	5.5	7.5		54	51	49	47	44	41	37	37~54
BL(T)20-5	5.5	7.5		67	62	60	58	55	50	45	45~67
BL(T)20-6	7.5	10		81	75	73	70	66	61	55	55~81
BL(T)20-7	7.5	10		95	89	86	82	77	71	65	65~95
BL(T)20-8	11	15		109	102	99	94	89	82	75	75~109
BL(T)20-10	11	15		136	128	124	118	111	103	95	95~136
BL(T)20-12	15	20		164	154	149	142	133	124	114	114~164
BL(T)20-14	15	20		192	180	174	166	156	145	133	133~192
BL(T)20-17	18.5	25		234	219	212	202	190	177	162	162~234

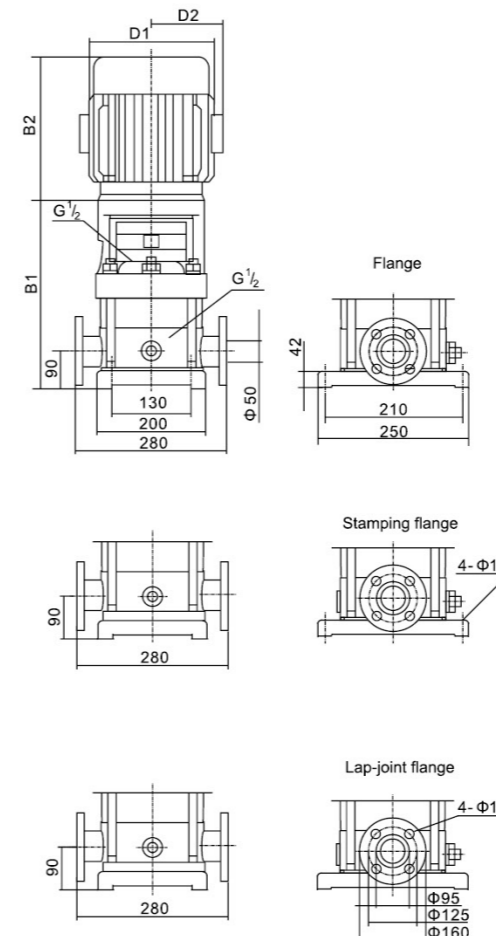

Dimensions & Weight

Model	Dim.(mm)					N.W.(kg)
	B1	B2	B1+B2	D1	D2	
BL(T)20-2	410	300	710	166	115	46/53
BL(T)20-3	465	355	800	212	140	61/68
BL(T)20-4	536	395	931	258	163	79/87
BL(T)20-5	581	395	976	258	163	81/88
BL(T)20-6	626	395	1021	258	163	84/94
BL(T)20-7	671	395	1066	258	163	86/95
BL(T)20-8	747	498	1245	315	251	162/170
BL(T)20-10	837	498	1335	315	251	165/173
BL(T)20-12	927	498	1425	315	251	180/186
BL(T)20-14	1017	498	1515	315	251	183/189
BL(T)20-17	1152	542	1694	315	251	203/211